

Whether it's car audio or home theatre, a LYNX Electronic Display Solution lets you showcase technology at it's best. Nothing is more compelling than being able to see, hear and experience technology first hand. It lets customers investigate different options and the full range of each product's capabilities. And for you, it is the ultimate merchandising tool – creating an impressive display that encourages customers to stay longer so you can ring-up the sales.

Each switching solution comes as one complete kit, and can be easily assembled without the help of a professional. And where our competitors sometimes use eight separate modules, we can use one. Which means it's less complicated, and more reliable.

LYNX supplies home theatre and car audio Electronic Display Solutions to Best Buy – one of the largest specialty retailers of consumer electronics in North America. The Best Buy group has more than 940 retail stores across USA and Canada, reaching an estimated 300 million customers each year, and revenue of US\$30 billion a year.

LYNX also supplies car audio Electronic Display Solutions to Fry's Electronics. Fry's is a leading electronics mass merchandiser with 32 stores on the West Coast of USA, stocking over 50,000 different SKU items.

**FSCA4**
**Small Car Audio Display**
**Call For Price**

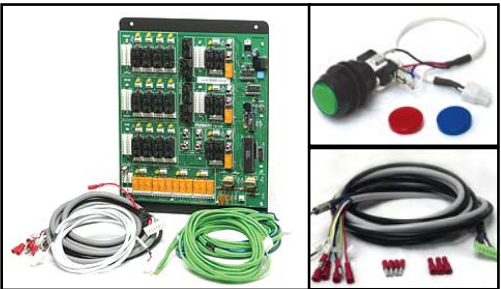

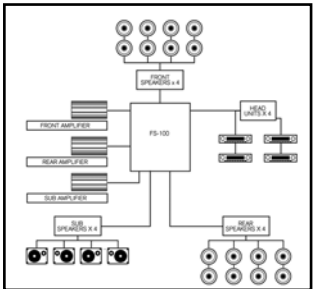

**"All In One" switching board. Button by product control. Illuminated LED indication buttons. Audible product selection chirp. Built in antenna distribution/switching. Built in DC power distribution. Expandable.**

<b>Capabilities:</b>		<b>Contents:</b>	
• Head Units	4	• FS100 Board	1
• Front Speakers	4	• 8' Head Unit Harnesses	4
• Rear Speakers	4	• 16' Speaker Harnesses	12
• Subwoofers	4	• 8' Amplifier Looms	3
• Front Amps	1	• Fusion Product Indicators	19
• Rear Amps	1	• 8' & 16' Switch Extensions	19
• Sub Amps	1	• 1 Meter Power Loom	1
		• Drill Bit For Product Indicators	1

**FSCA6**
**Medium Car Audio Display**
**Call For Price**

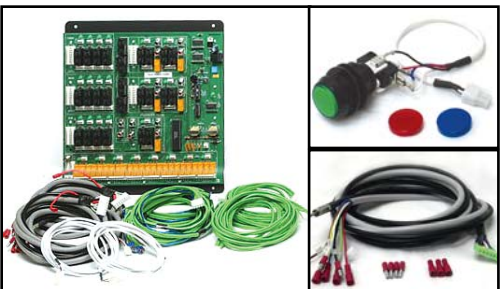

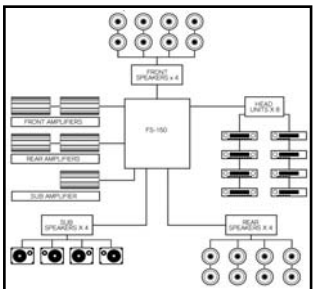

**"All In One" switching board. Button by product control. Illuminated LED indication buttons. Audible product selection chirp. Built in antenna distribution/switching. Built in DC power distribution. Expandable.**

<b>Capabilities:</b>		<b>Contents:</b>	
• Head Units	8	• FS150 Board	1
• Front Speakers	4	• 8' Head Unit Harnesses	8
• Rear Speakers	4	• 16' Speaker Harnesses	12
• Subwoofers	4	• 8' Amplifier Looms	5
• Front Amps	2	• Fusion Product Indicators	25
• Rear Amps	2	• 8' & 16' Switch Extensions	25
• Sub Amps	1	• 1 Meter Power Loom	1
		• Drill Bit For Product Indicators	1

**FSCA8**
**Large Car Audio Display**
**Call For Price**



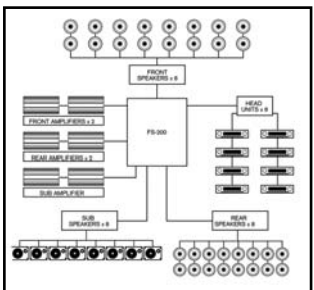

**"All In One" switching board. Button by product control. Illuminated LED indication buttons. Audible product selection chirp. Built in antenna distribution/switching. Built in DC power distribution. Expandable.**

<b>Capabilities:</b>		<b>Contents:</b>	
• Head Units	8	• FS200 Board	1
• Front Speakers	8	• 8' Head Unit Harnesses	8
• Rear Speakers	8	• 16' Speaker Harnesses	24
• Subwoofers	8	• 8' Amplifier Looms	6
• Front Amps	2	• Fusion Product Indicators	38
• Rear Amps	2	• 8' & 16' Switch Extensions	38
• Sub Amps	2	• 1 Meter Power Loom	1
		• Drill Bit For Product Indicators	1

**Also available...**

<b>FSCAHD8</b>	<b>FSCAAM4</b>	<b>FSSPK4P</b>	<b>FSMP3SPK&amp;HP8</b>
<b>Call</b>	<b>Call</b>	<b>Call</b>	<b>Call</b>
<b>8-Way Head Unit Switcher</b> <i>Stand Alone or Expansion Module</i>	<b>4-Way Amplifier Switcher</b> <i>Stand Alone or Expansion Module</i>	<b>4-Way Speaker Switcher</b> <i>(Also Available)</i> <i>Stand Alone or Expansion Module</i>	<b>8-Way MP3 Player Switcher</b> <i>With Speaker OR Headphone Output</i>
<b>FSHT8</b>			<b>Call</b>
			<b>8-Way Home Theatre Switcher</b>

